

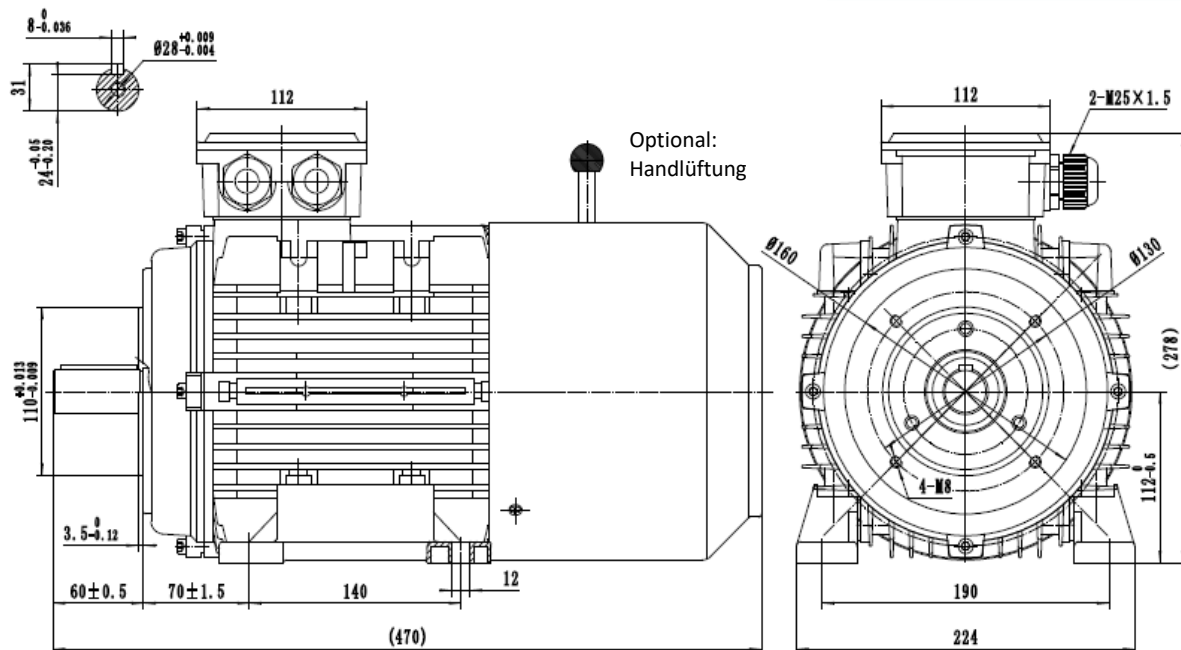

Drehstrombremsmotor / Three-Phase-Brakemotor

IE3 - 1,5 kW - 8 polig / 8 pole B34



Typ / type **SEV-BM3 112M-8**

| | | | | |
|--|------------|----------------------------|--|--|
| Gehäusematerial / frame material | | Aluminum | Nenn Drehmoment / rated torque | 20,03 |
| Ausführung / execution | | Dreiphasen/ three phase | Anzugs- zu Nennmoment / start- to rated torque | 2,3 |
| Baugröße / frame size | | 112 | Kipp- zu Nennmoment / brakedown- to rated torque | 2,7 |
| Leistung / power @50Hz | kW | 1,50 | min. Dreh- zu Nennmoment / min- to rated torque | 1,9 |
| Nennstrom / rated current @230V | Δ | 7,24 | Anzugs- zu Nennstrom / starting- to rated current | 5 |
| Nennstrom / rated current @400V | Y | 4,18 | Lager / bearing (DE) | 6306-2RZ |
| Drehzahl / speed @50Hz | (r/min) | 715 | Lager / bearing (NDE) | 6206-2RZ |
| Wirkungsgrad / efficiency | IE3 | | Wellendichtung / shaft seal (DE/NDE) | 30x44x7 |
| | Eff. 100% | 79,70 | Hauptkabelverschraubung / main cable glands | 2-M25*1.5 |
| | Eff. 75% | 78,90 | Isolationsklasse / insulation class | F |
| | Eff. 50% | 76,90 | Schutzart / protection degree | IP 55 |
| Leistungsfaktor / power factor cosφ | 100% load | 0,65 | Thermischer Schutz / thermal protection | 3*PTC |
| 60Hz 265/460V | Power(kW) | 1,73 | Drehrichtung / rotation direction | rechts-links / clockwise-counterclockwise |
| 60Hz 276/480V | Power(kW) | 1,80 | Einschaltdauer / service duty | S1 |
| Drehzahl / speed @60Hz | (r/min) | 860 | Wuchtung / balance | Halbkeilwuchtung / half-key balanced |
| Ausführung Bremse / execution brake | | BLC457-14 | Kühlungsart / cooling | IC 411 |
| Bremsmoment / braking torque (@ 100 Upm / rpm) | | 60 | Lautstärke / noise dB(A) | 61 |
| Normen / regulations | | IEC / DIN / ISO / VDE / EN | Nettogewicht / net weight(kg) | 38,41 |
| Standard / standard | | IEC 60034 | Massenträgheitsmoment / moment of inertia (kg*m ²) | 0,017675430 |
| Umgebungstemperatur / ambient Temp. | | -20°C ~ +40°C | Aufstellungshöhe / altitude (max.) | 1000m über Meeresspiegel / above sea level |